



TURBO SEPARATOR

Depackaging and Pre-Processing
System for Organic Waste Recycling

RATES UP TO 25 TON PER HOUR



- Made in USA
- Efficient Horizontal Design
- 99% Separation/99% Clean Organics
- No Water Required
- Low Wear/High Uptime

See videos on



"turborecycling"

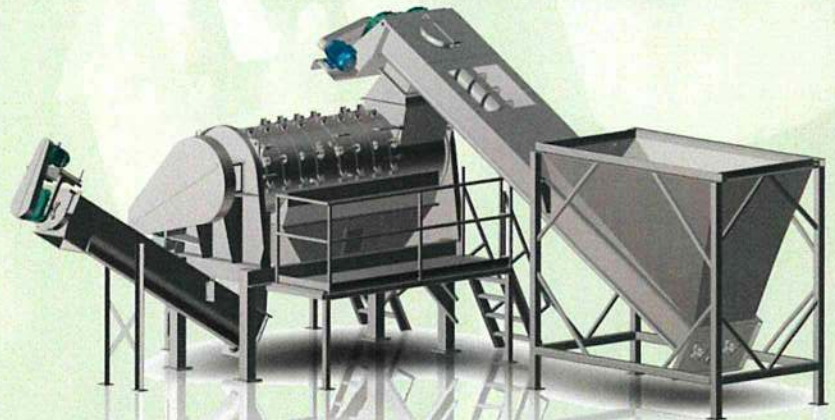

Over 300 systems sold –worldwide leader



605 4th Avenue NW | New Prague, MN 56071 | 800.394.2591
www.turborecycling.com

| APPLICATION | INCOMING FOOD WASTE | | |
|--------------------|---------------------|---------------|-------------|
| QUESTIONS | WET GOODS | DRY GOODS | MIXED WASTE |
| TONS/DAY | | | |
| SHIFTS/DAY | | | |
| TONS/HOUR | | | |
| METHOD | WHEEL LOADER | WALKING FLOOR | |
| RECOVERED ORGANICS | | | |
| DESTINATION | ANIMAL FEED | A. DIGESTER | COMPOST |
| METHOD | CONVEYOR | PUMP | CONVEYOR |

ESTIMATED SYSTEM COST:

LEASING AND RENTALS AVAILABLE

| WITH TWIN SCREW CONVEYOR | | | | |
|--------------------------|-------|-------|--------|--------|
| 460V | T20 | T30 | T42 | THOR |
| Full Load AMPS | 65.6 | 104.2 | 148.4 | 176.4 |
| kW (460V) | 52.27 | 83.02 | 118.23 | 140.55 |
| 575V | T20 | T30 | T42 | THOR |
| Full Load AMPS | 52.8 | 88.8 | 124.3 | 146.3 |
| kW (575V) | 52.59 | 88.44 | 123.79 | 145.7 |

| | T20 | T30 | T42 | THOR |
|----------------|-----|-----|-----|------|
| RATE-TON/HR | 5 | 10 | 20 | 20 |
| INFEED | | | | |
| TWIN SCREW | | | | |
| DRAG PADDLE | | | | |
| CLEATED BELT | | | | |
| SINGLE SCREW | | | | |
| WASTE | | | | |
| 12' SINGLE | | | | |
| 16' SINGLE | | | | |
| 20' SINGLE | | | | |
| BELT | | | | |
| ORGANICS | | | | |
| 12' SINGLE | | | | |
| 16' SINGLE | | | | |
| 20' SINGLE | | | | |
| 24' SINGLE | | | | |
| PUMP | | | | |
| BOERGER | | | | |
| WASTECORP | | | | |
| WASTECORP HD | | | | |
| GRIT SEPARATOR | | | | |
| WALKING FLOOR | | | | |

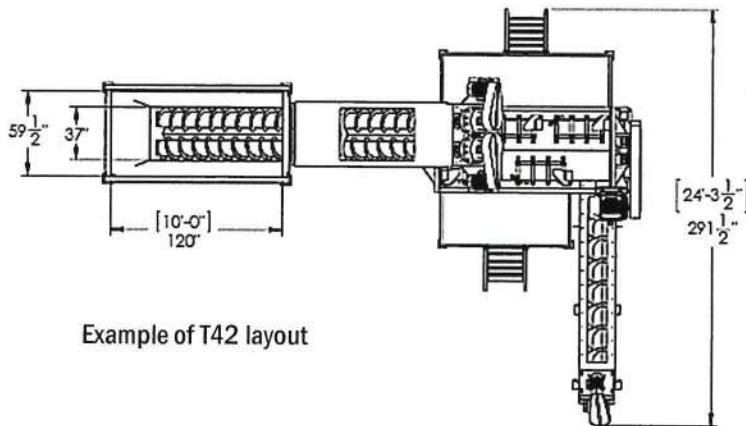

Example of T42 layout

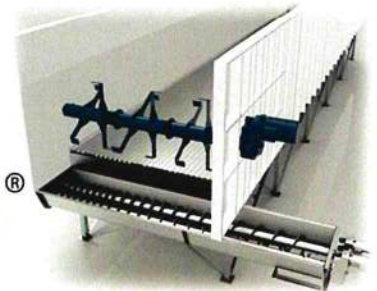
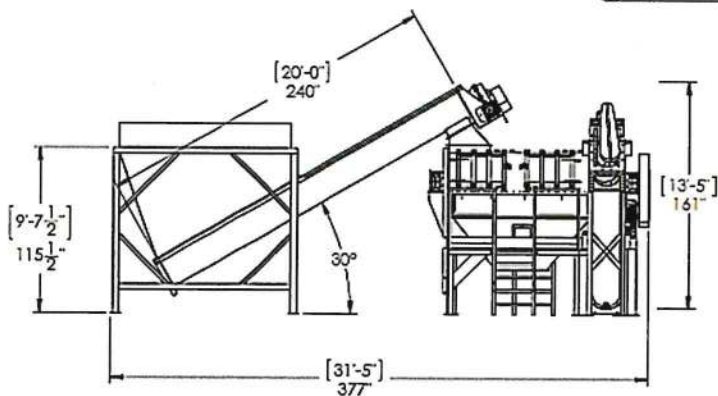

KEITH WALKING FLOORS FOR ORGANICS RECEIVING

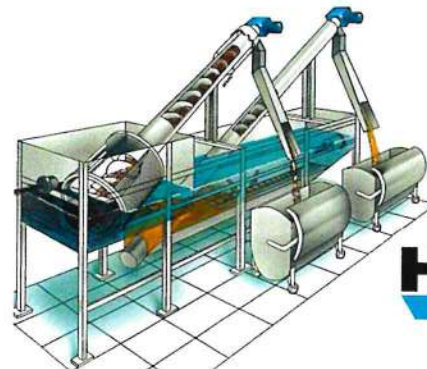

HUBER TECHNOLOGY SEPARATORS FOR GLASS AND PLASTIC
HUBER GRIT WASHING SYSTEMS FOR BOUSED ORGANICS



Call (952) 758-2591 - Ask For Turbo Sales

For more information: www.turborecycling.com