

Quadro Comil®

ADVANCED SIZE REDUCTION • PERFORMANCE & FLEXIBILITY

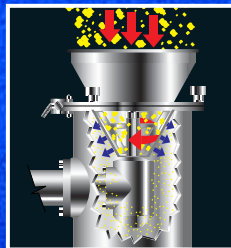
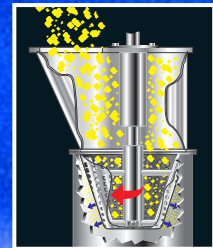

The Industry Standard for Over a

Used by global leaders in more than 50 countries, the *Quadro® Comil®* is the world's leading technology for achieving uniform size reduction, sieving, deagglomeration dispersion and mixing. In applications throughout the Pharmaceutical, Food, Fine Chemical, Personal Care and Cosmetics industries, wherever process managers seek optimum process efficiency and product consistency – that's where the *Comil®* is hard at work.

Maximum processing efficiency

Quadro invented the original conical mill in 1976. Though simple in principle, the *Comil®* was a revolutionary concept that has since evolved into a global processing standard adopted by market leaders around the world. Today, the *Comil®*'s proprietary, advanced size reduction technology has been refined through thousands of applications to deliver reliable scalability, repeatability and environmentally friendly performance. The result is superior product quality and maximum throughput for quick return on investment.

Versatility and control

Over the past 25 years, the *Comil®*'s industry leadership has been reaffirmed with every new product generation introduced. Our latest inline designs incorporate a host of innovations that offer greater application versatility along with easier cleaning and maintenance.

Maximum performance

When you choose the *Quadro® Comil®* you can rely on receiving the superior engineering and manufacturing quality that give you maximum uptime and yield. What's more, every *Comil®* is backed by the highest level of application and technical support, based on more than a quarter century of Quadro experience.

Quadro® Comil® products are patented worldwide.



THE QUADRO® COMIL® HERITAGE

Revolutionary technology that has stood the test of time

1976



Model 196
First *Comil®* brought to market

1977



Model 197
Small production model introduced

1984

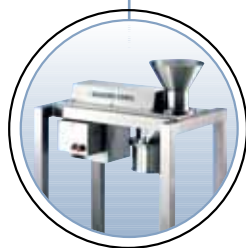

Model 194
Mid-size production model introduced

1990



Model U20
Comil® underdriven line established

1993

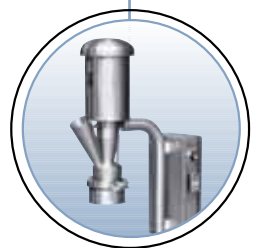

Model 193
Smaller lab-scale model introduced

Quarter Century



The Quadro® Comil® comes in 35 standard models, available with over 200 screen types and dozens of different impellers – the industry's most extensive line of conical milling equipment.

DYNAMIC PRINCIPLES

1. In the conical screen chamber, a rotating impeller imparts a vortex flow pattern to the infeed product.
2. The product is forced outward to the screen surface by centrifugal acceleration, ensuring continuous delivery into the "action zone" between the screen and impeller.
3. In the "action zone" the material is uniformly sized and instantaneously passed tangentially through the screen openings.
4. The finished product is discharged at the bottom of the milling chamber.



1996

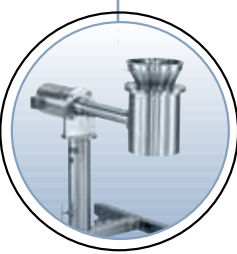

Series 2000
Comil® global design

2001

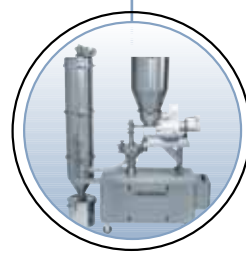

Model F10
Fine Grind Series,
micron milling

2003

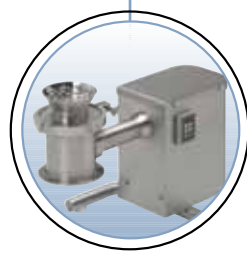

Model U5
First scalable lab
size cone mill

Comil® Overdriven

Quality engineered for reliable, low-maintenance operation, the Comil®'s track record for high-efficiency inline processing is unequaled across a vast range of applications – from size reduction to mixing and dispersion, bulk density adjustment to separation and reclaim.

Scalable performance

The Comil® Overdriven is available in five models, offering capacities up to 120,000 lb/hr (54,500 kg/hr). Specialized performance options are also available.

Manufactured in stainless steel for sanitary operation and easy cleanability, the Comil® Overdriven can be flood fed (control feeding is not necessary). Milling action can be fine tuned using a comprehensive selection of interchangeable tooling, as well as speed variation.

Low heat, low noise, low dust

The original Comil®'s innovative, low-speed design applies an inherently gentle action to the product, achieving optimum particle granulometry while generating limited or no heat, low noise and minimal fines. In addition to low energy consumption, the result is a consistent, high-quality end product, even with heat-sensitive materials.



Direct overdriven models (no belts) are available for capacities up to large production sizes.



SPECIFICATIONS

		MODEL				
		197	194	196	198	199
CAPACITIES	lb/h	up to 800	up to 4,000 ^(3a)	up to 8,000 ^(3b)	up to 16,000 ^(3c)	up to 32,000 ^(3d)
	kg/h	360	1,800 ^(3a)	3,600 ^(3b)	7,200 ^(3c)	14,400 ^(3d)
APPROXIMATE DIMENSIONS	(LxWxH) in.	22.5x12.5x31.6	41.5x27.5x63	50x27.5x68.5	68x35x68	84x46x83
	(LxWxH) mm	572x318x802	1050x700x1620	1270x700x1740	1730x890x1730	2130x1170x2110
SCREEN DIAMETER	inches	5	8	12	24	30
	mm	127	203	305	609	761
POWER	Hp	2	5	10	20	30
	kW	1.5	4	7.5	15	22
EQUIPMENT SCALE-UP FACTOR		1	5	10	20	40

FEATURES

⁽¹⁾ Capacities are based on standard pharmaceutical placebo with 3% crystalline cellulose (CMC).

⁽²⁾ Capacities may vary significantly based on product characteristics, particle granulometry, inlet and discharge conditions. Consult your local representative or Quadro for product testing.

⁽³⁾ For some products, capacities reach the following higher limits: ^(a)15,000 lb/h (6,800 kg/h), ^(b)35,000 lb/h (15,900 kg/h), ^(c)60,000 lb/h (27,000 kg/h), ^(d)120,000 lb/h (54,500 kg/h).

PROVEN SIZE REDUCTION TECHNOLOGY



- 1 Infeed chute can be customized to meet all process feed requirements (manual, pneumatic or mechanical).
- 2 Machine housing with super-sanitary spindle assembly. Can also be modified for clean-in-place (CIP) operation.
- 3 Swing-away discharge shroud allows quick changeover of screens, impellers, customized tooling for special applications. Also allows for easy cleaning. Can be custom engineered to fit any process or collection vessel.
- 4 Entire machine available in various grades of stainless steel and specialty alloys.
- 5 Belt guard – compact for easy removal, gasketed for added protection of drive components. (See inset for illustration of direct driven model.)
- 6 Safety features to meet all international safety guidelines and standards.
- 7 Stainless steel motor shield for sanitary applications.

SOLUTION PROFILE



DELUMPING DOWN TO <500 MICRONS

"When we replaced our oscillating granulator with a Comil® for delumping sodium and potassium chlorides, the results were impressive. Dust levels were minimized, and equally if not more important, processing time was reduced by 50%."

Norgine Ltd., South Wales, U.K.

To achieve the tight particle size range required to produce their "Movicol" product, Norgine had been delumping chlorides in small batches using an oscillating granulator. The Comil® performed so well, that they purchased a second unit for sizing dried granules for their "Camcolit" and "Destolit" tablets.

METHOD OF OPERATION

Sodium and potassium chlorides are dried on trays, then tipped into the inlet of the Comil® through a specially designed feed hopper, reducing dust levels to an absolute minimum.

**Comil® Model 197 S
with standard feed hopper**



Comil® Underdriven

Based on the same revolutionary technology as our overdriven model, the Comil® Underdriven provides all the features and options of the original Comil® – with additional advantages, including easier inline integration.

Compact design, increased throughput

This mill's advanced, compact design and extremely short head height provide for easy integration into processing environments where head room is limited. A large-diameter infeed and "straight through" housing (with no offset between inlet and outlet) promote unhindered inline product flow for quicker discharge.

Available in four models, the Comil® Underdriven is scalable in capacity from several ounces (grams) to 35,000 lb/hr (15,900 kg/hr).

Innovative "quick change" tooling

Fine tuning the mill for optimum granulometry is simplified by means of an innovative spacerless design, which allows for quick changeover of impellers and screens. Specialized tooling is available to meet all process requirements. A variable-speed feature provides for even greater control of process performance.



FEATURES

SPECIFICATIONS

		MODEL				
		U3	U5	U10	U20	U30
CAPACITIES	lb/h kg/h	from 100 gm or 3 oz batches	up to 425 195	up to 850 390	up to 4,250 ^(3a) 1,950 ^(3a)	up to 8,500 ^(3b) 3,900 ^(3b)
MINIMUM INLET TO OUTLET HEIGHT	inches mm	9 229	11 179	10.5 267	14.5 368	19.5 495
SCREEN DIAMETER	inches mm	2.55 65	3.25 83	5 127	8 203	12 305
POWER	Hp kW	.33 0.246	0.5 0.375	2 1.5	5 4	10 7.5
EQUIPMENT SCALE-UP FACTOR		0.5	1	2	10	20

⁽¹⁾ Capacities are based on standard pharmaceutical placebo with 3% crystalline cellulose (CMC).

⁽²⁾ Capacities may vary accordingly based on product characteristics, particle granulometry, inlet and discharge conditions. Consult your local representative or Quadro for product testing.

⁽³⁾ For some products, capacities reach the following higher limits: ^(a)15,000 lb/h (6,800 kg/h),

^(b)35,000 lb/h (15,900 kg/h).

⁽⁴⁾ U3 model is generally designed for lab and research purposes.

HIGH CAPACITY IN A COMPACT FOOTPRINT

The Comil® Underdriven's cGMP design and minimum surface area of contact make it easy to clean, as well as offering quick disassembly and assembly for autoclave applications.



- 1 Extremely short housing height for installation in production environments where space is limited.
- 2 Large infeed diameter for up to 50% higher capacity than conventional mills.
- 3 Spacerless design provides optimum impeller/screen gap for superior particle granulometry and performance.
- 4 Minimum surface area resulting in maximum product flow and lower cleaning costs.
- 5 Easy-clean, sanitary design includes all sanitary connections and ultra-sanitary gearbox. Fully automatic CIP capability available.
- 6 Quick changeover of screens and impellers, no special tools required.
- 7 Inlet and outlet can be customized to fit any process conditions.
- 8 Safety features to meet all international guidelines and standards.

SOLUTION PROFILE



SAFE, VERSATILE INERT MILLING

"Not only did the Quadro® Comil® meet our most stringent requirements for use in hazardous locations, the portable design of the system allowed for remarkable flexibility, along with easy operation and cleaning."

Pfizer Inc., Michigan, U.S.A.

When Pfizer required a portable inert mill for use throughout their new, state-of-the-art research facility in Michigan, they turned to Quadro. We engineered a custom solution that included an air-purge electrical panel, inert gas inlet and outlet ports, a closed-loop oxygen control system, and infeed chutes for both inline and hand feeding.

METHOD OF OPERATION

Prior to starting, the Comil® is purged with N₂ in order to produce inert operating conditions. During milling, should the oxygen level rise to the preset maximum, the N₂ purge is activated automatically to halt the rise. Should this continue, an alarm will sound and the Comil® will shut down.

Comil® Model U10



Leading Expertise Gained Through More Than 20,000 Applications

For more than 25 years, Quadro has been continually refining and improving *Comil*[®] technology. During this time, we have partnered with our customers, successfully developing thousands of custom applications to provide increased productivity, versatility and reliability.



In our state-of-the-art testing center, Quadro performs advanced application testing and analysis for our customers, at no charge.

Application problem solving

Unparalleled experience enables us to offer a level of application problem-solving expertise second to none – whether you're reclaiming pharmaceutical powders from gelatin capsules, performing closed-loop inert milling, granulating freeze-dried food products with minimum retention time or delumping wet, sticky materials.

Processing knowledge

In designing for your application, Quadro engineers draw on one of the most comprehensive databases of processing knowledge. Our industry-leading global test center includes a full range of the latest lab equipment, a product preparation area and a state-of-the-art analysis area, as

well as a fully equipped customer training and testing facility, all dedicated to optimizing your production process.

Try before you buy

To enable our customers to evaluate the *Quadro*[®] *Comil*[®] in a real-world production environment, we offer a "try before you buy" trial tooling and rental program. Our confidence in the *Comil*[®]'s ability to meet or exceed your expectations, and perform trouble-free processing, enables us to offer a full money-back guarantee.

DRY MILLING SIZE REDUCTION

Dry granulation in tablet manufacturing. Dry solubles. High-throughput bulk density fine tuning. Sizing dry granules. Sizing compacted product.

WET MILLING SIZE REDUCTION

Size reduction and milling of wet or soaked products to produce liquid with wet suspended particulate. Powders into pastes. Wet blending. Uniform sizing of wet granulation in tablet manufacturing.

DRY MIXING DISPERSION

Ideal for a broad range of dry mixing, finishing and dispersion tasks. Lump-free homogeneous blending to precise size requirements. Low heat buildup and precise screen size ensure complete dispersion at desired particle size.

DEAGGLOMERATION DELUMPING & SEPARATION

Reducing difficult, sticky, heat-sensitive agglomerates into pieces, crumbs or powders of uniform size, continuously without excessive heat buildup or screen blockage. Preserves quality of fragile products. Replaces labor intensive, expensive manual processes.

RECLAIM

Gentle breaking action enables the *Comil*[®] to powderize heat-sensitive products such as shortening and cream filled products. Hard, compacted products can also be size reduced with minimal fines.

APPLICATION SHOWCASE

PHARMACEUTICAL

Size reduction of compacted slugs (*shown*)
 Size reduction of "ribbons" from the roller compactor
 Sizing dry granulation to ideal particle size for tableting

Sizing of injectable drug powder in sterile production
 Gentle size reduction of enzymes
 Sizing lactose and other sugars



Uniformly size wet granulation for efficient drying (*shown*)
 Size reduce frozen blood plasma



Homogeneously disperse pigments in tablets (*shown*)



Delump raw materials exiting bulk bins (*shown*)



Tablet reclaim (*shown*)
 Contents from capsules
 Injectable drug from glass syringes and bottles



FOOD

Producing crumbs from dry cereal or bread for food coatings (*shown*)
 Sizing chili peppers into flakes
 Fine tune bulk density of non-dairy creamer

Powderize shortening flakes
 Gentle size reduction of freeze-dried bacteria culture
 Size reduce herbs for extraction



Size reduce berries for yogurt filling (*shown*)
 Produce lump-free tofu cream
 Mill soaked soya beans to produce soy milk product



Homogeneously disperse fat globules in bakery mixes (*shown*)
 Gentle blending of spice mixes



Disperse nutrients in cereal
 Uniformly disperse spice, flavors or pigments in pudding mixes



Separate raisin clumps into undamaged individual pieces (*shown*)



Deagglomerate cheese powder from spray dryer
 Size chocolate milk crumb prior to flaker
 Separate dried fruit without damage



GENERAL • COSMETIC • CHEMICAL

Size reduce mineral salts (*shown*)
 Uranium dioxide milling

Dried citric acid milling
 Size reduce yew needles



Deagglomerate centrifuge cake (*shown*)
 Wet core dishwasher detergent



Homogeneously disperse binder pearl and pigments in blush and eye shadow powders (*shown*)

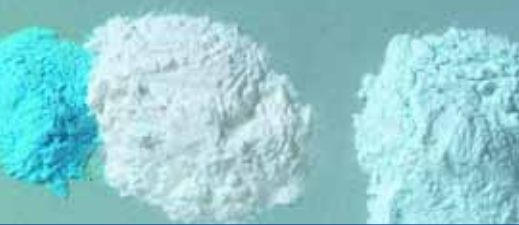

Deagglomerate pigments (*shown*)
 Delump detergent agglomerates



Delump metal powders (e.g., silver)
 Delump Teflon® powder



Powderize laundry detergent (*shown*)
 Produce slurry from scrap detergent lumps
 Dry dog food reclaim



Custom Engineered Solutions Tailored to Your Specific

Quadro excels in custom engineering. From simple dimensional changes of our standard models to complete prototype development, we offer unmatched application expertise that enables us to build to your exact process requirements.

Performance, repeatability, flexibility

Our experience in conical-screen size reduction is unequalled. Every *Comil*[®] is engineered for superior performance and reliability. No matter what your application, the *Comil*[®] consistently



Quadro custom engineered this integrated milling solution incorporating the Comil[®] with a Carlisle Extract crossflow system.

delivers the batch-to-batch repeatability required to comply with the most demanding FDA standards.

Since 1976, the *Comil*[®] line has expanded to include thirty-five base models. Model selection is tailored to

meet your specific performance and volume demands. For example, by interchanging tooling you can alter size reduction, blending or dispersion parameters to handle varying product requirements, or even completely different applications, all using the same machine.

An array of specialized options

We offer a comprehensive selection of specialized options for customizing the *Comil*[®] to your exact needs.

Options include:

- Special materials and surface finishes
- Portable, height-adjustable and slide-rail mounted frames
- Pressure-vessel, explosion proof, fully inert, totally contained glove-box and cryogenic mill designs
- Computerized control for complete process monitoring and reporting.

Available in USDA approved, CIP, SIP and WIP designs, the *Quadro*[®] *Comil*[®] conforms to all international standards including UL, CSA and Halal certifications, and complies with OSHA, FDA, CE, cGMP, ATEX and 21CFR11 guidelines and directives.

Detailed documentation, such as compliance certificates and IQOQ documents, is available in various languages to make your validation process easier.



The unmatched flexibility of the Comil[®] design enables

TYPICAL SYSTEM



Milling and Blending



Dry Milling and Conveying

Processing Needs



Quadro to provide highly customized solutions for integration into your most demanding processing environments.



An inverted fluid-bed dryer bowl directly discharges into a Comil® U30 on a portable stand, feeding a stainless steel drum.

CONFIGURATIONS



Pressure Vessel (meets ASME code)



Integrated Wet Sizing



Bulk Discharge Station

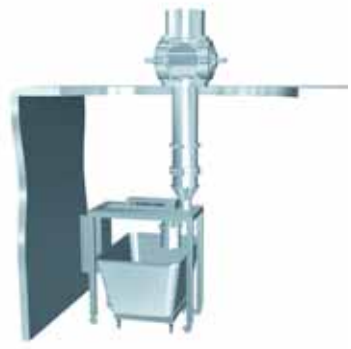

Finishing (Feed from Blender)



Complete Inert Milling System



Hazardous Containment

QUADRO PROCESS PRODUCTIVITY SOLUTIONS

For more than 25 years, Quadro has made an unparalleled commitment to delivering the highest production efficiencies, product quality and consistency to market leaders in the Pharmaceutical, Food, Fine Chemical, Personal Care and Cosmetics industries worldwide.



With the engineering experience gained from developing reliable application-specific solutions for major processors in more than 50 countries, our knowledge of size reduction and dispersion is unmatched. In fact, meeting the evolving needs of our customers drives the development of some of the industry's most advanced processing technologies and systems – such as the *Quadro*® *Comil*®, *Ytron*™ inline mixers, dispersers and emulsifiers and *Quadro Vac*® vacuum transfer systems.

Since 1976, Quadro has led the industry in research & development. Through the Quadro R&D Test Center we work

directly with our customers, to run real-world tests of their processes on the latest Quadro equipment. The result has been technical breakthroughs that have changed the way many of our customers process, and led to new global processing industry standards.



As the world's leading supplier of size reduction technology – with a vast global network of agents, distributors, OEMs and partners – Quadro provides a level of service and technical support that is unequaled in the industry. Our passion for technology is exceeded only by our dedication to meeting the needs of our customers.

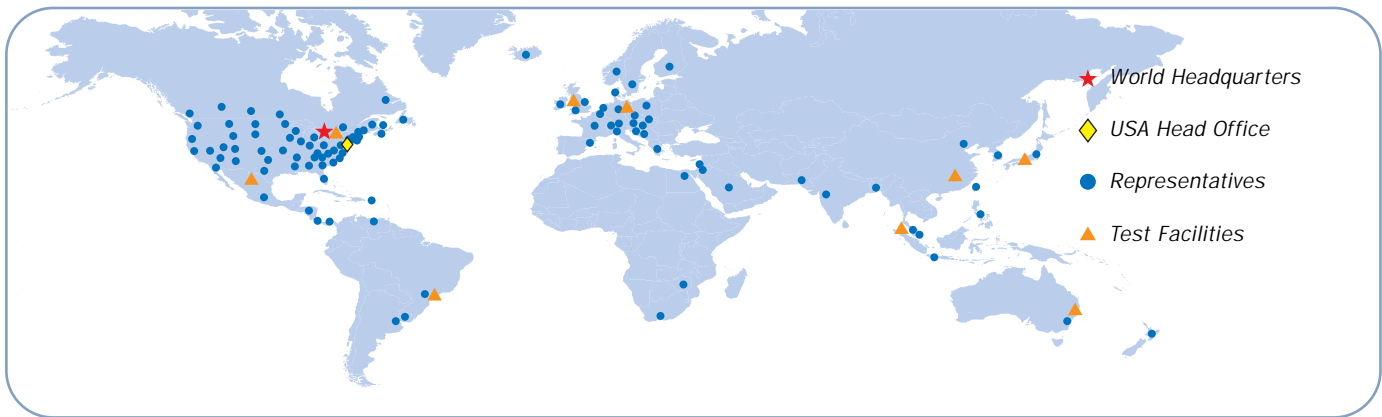

SIZE REDUCTION • FLUID MIXING • PNEUMATIC TRANSFER



LOCAL REPRESENTATIVE



Quadro Engineering
613 Colby Drive
Waterloo, ON, CA N2V 1A1
T 519-884-9660
F 519-884-0253
sales@quadro.com
www.quadro.com

Quadro (US) Inc.
55 Bleeker Street
Millburn, NJ, USA 07041-1414
T 973-376-1266
F 973-376-3363
sales@quadro.com
www.quadro.com