

Plow Mixer

Improve your process with the Scott Plow Mixer

The Scott Plow Mixer's insightful design incorporates high intensity wedge-shaped plows to deliver a fluidized mixing zone. The mixer shaft operates at higher speeds than a traditional batch mixer, and when incorporated with the cylindrical vessel design, it delivers excellent mixing results.



- Custom manufactured in carbon steel, 304 stainless steel or 316 stainless steel
- Full sanitary designs available up to 3A Dairy standard
- Optional high speed choppers aid mixer performance as they de-agglomerate and assist in the distribution of liquids being mixed
- Full clamshell access door allows top third of mixer to open for easy cleaning and maintenance
- Versatile design for either batch or continuous process
- Optional high pressure steam or water jackets for heating or cooling applications
- Scott Test Lab Facilities are available to the customer for a full range of product testing and analysis

Only Our Best Ingredients
to Mix Yours

Plow Mixer



Clamshell and hinged-door designs are sanitary and allow for complete mixer access. Safety limit switches are provided on all mixer access points.

The fluidized bed created by the mixing action offers the product excellent surface area coverage on the mixer cylinder. This action greatly increases the efficiency of the jacketed unit to act as a drying or cooling vessel.

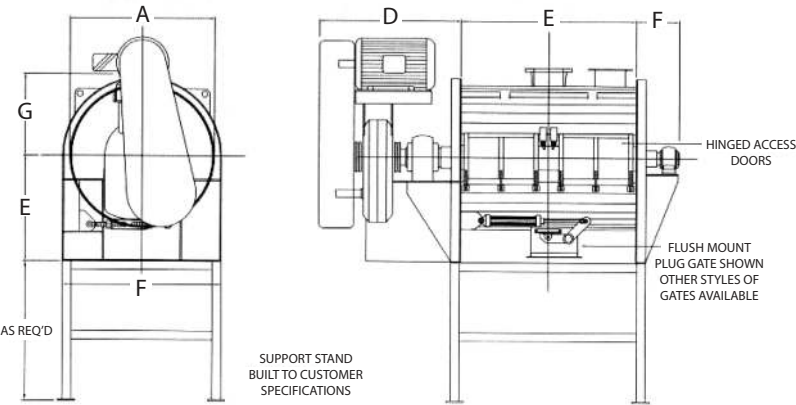

	SIZE	A	B	C	D	E	F	G	CAPACITY
PL243	24" x 30"	24	36	12	32	22	28	15	6 CU.FT.
PL304	30" x 48"	30	48	14	40	26	36	19	10 CU.FT.
PL364	36" x 48"	36	48	14	40	30	42	22	18 CU.FT.
PL488	48" x 96"	48	96	15	44	36	54	28	65 CU.FT.
PL4810	48" x 120"	48	120	15	44	36	54	28	82 CU.FT.
PL5410	54" x 120"	54	120	16	50	40	60	31	100 CU.FT.
PL6012	60" x 144"	60	144	16	54	44	66	34	150 CU.FT.

Dimensions are for reference only. Additional sizes available.



For more information, please contact us:
 605 4th Avenue NW, New Prague MN 56071
 Phone: (800) 394-2591 (952) 758-2591
 Fax: (952) 758-4377
 E-mail: Sales@ScottEquipment.com
 Or visit our website at www.scottequipment.com

Innovative Solutions for Your
 Processing Challenges