

PNEU-CON ***PNEUMATIC*** ***CONVEYING, INC.***



POWDER WHISPER® LOADERS

POWDER WHISPER® LOADERS

Self-Contained Powder Whisper Loaders Offer Dust-Free Handling of Powders

Self-Contained Powder Whisper Loaders™ are designed for dust-free handling of difficult-to-handle fine materials and powders. Powder Whisper Loaders are fully assembled and ready for immediate use.

- Feed rates from 50 - 3000 pounds per hour.
- Special inlet, Semi-TE, Box-TE, and abrasion-resistant options are available.
- 60° cone design, mounting flange and discharge valve.
- 70° cone and mounting brackets are optional.
- Filter cartridges are tubesheet mounted and lightweight for easy removal and replacement.
- Filter cartridge types and media are available for most applications.
- The Vibra-Pulse™ Automatic Filter-cleaning System consumes 0.5 SCFM @60 PSI of dry, filtered compressed air for each cycle. (Compressed air source not included)
- Standard Vacuum source is a durable brush-type motor for high conveying rates, long service life & low maintenance.
- PLC-based Electrical Control Panel, NEMA 1 Hinged Enclosure (Options: Choose from a variety of PLC-based control modules and NEMA rated enclosures).
- Variable speed control option is available.
- Pick-up Lance and clear food-grade PVC flexible hose with an integral ground wire.

Available in aluminum, carbon and stainless steel with 120 or 240 voltages.

Partial List of Materials Conveyed by Powder Whisper Loaders

Calcium Carbonate
Cellulose Powders
Cereals
Cocoa
Coffees

Cosmetics
Epoxy Resins
Flours
Powdered Cheeses
Powdered Milk

Protein Powders
Rice
Salts
Silica
Spices

Sugars
Teas
Titanium Dioxide
Toners
Vitamins

Automatic Vibra-Pulse Filter Cleaning System

Every Pneu-Con Powder Whisper® Loader comes complete with a continuous Automatic Vibra-Pulse™ Filter-cleaning System built into the Cover Assembly.

During a timed cycle, a burst of compressed air (or pulse-jet) is directed down through the top of the Filter Cartridge element. This induces clean air flow into the filters, setting up a pneumatic shock wave inside the element.

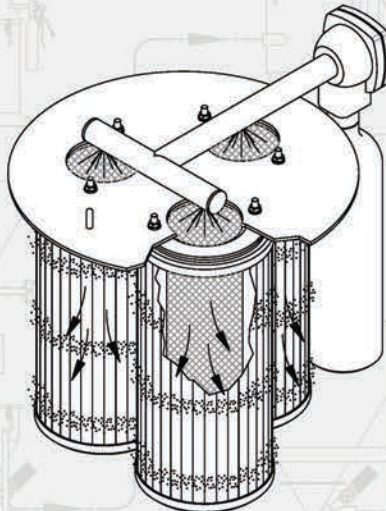

The filtered air flow is momentarily halted, and the Filter Media is firmly flexed causing accumulated dust particles to drop from between the pleats into the hopper below.

A Jumper added to the Controller Inputs gives the user the option to have ON-Line and/or OFF-Line Pulse as required to match conveying needs.

Pneu-Con custom-designs, engineers and manufactures quality Pneumatic Conveying Systems including Central Powered Systems, Self-Contained Systems, Powder Loaders & Receivers, Bag Dump Stations, Blower Packages, Bulk Bag Racks, Day Bins, Silos, Tilt Stations (Drum & Gaylord), Weigh Hopper/Batchers, Volumetric/Gravimetric Blenders, Vertical Mixers, Rotary Airlocks, Railcar Unload Systems, Just-In-Time Conveying, Fines Separators and System Controls.

960 East Grevillea Court, Ontario, CA 91761 Ph: (909)923-4481 Fax: (909)923-4491

www.pneu-con.com